



# ***dVision 1080p***

**DIGITAL**  **PROJECTION**



2	Table of contents
3	Introduction
4	Safety & Warnings
8	Supplied material
9	Optional lenses
10	Overview
11	Keypad
13	Indicators
14	Remote control
16	Connector panel
17	Set up
18	Image adjustments
19	Lamp operation
20	Ceiling mount
22	Using the projector
44	Menu system
23	RS 232 and LAN control
24	Trouble shooting
25	Maintenance
26	Service information
27	Lamp change
28	Technical data
32	Declarations

This digital projector is designed with the latest state-of-the-art technologies in illumination, imaging, optics, electronics, thermal and industrial design in order to serve traditional as well as novel imaging applications across a variety of markets, offering features such as:

- PROFESSIONAL GRADE POWERED PROJECTION LENSES with bayonet mounts
- DUAL LAMP SYSTEM with separate lamps for improved life, redundancy and 24/7 operation
- DUAL OPTOMECHANICAL IRIS for variable contrast and brightness
- MECHANICAL SHUTTER for total black
- HD 1920 x 1080 pixel DLP™ technology
- SINGLE CHIP DMD™ with DarkChip™ technology by Texas Instruments®
- HIGH CONTRAST for vibrant colors and deep blacks
- HIGH RESOLUTION for unprecedented detail
- HIGH BRIGHTNESS for larger screens
- DEEP BLACKS for maximum dynamics
- REDUCED IMAGE NOISE through high end signal processing
- ECO MODE for reduced power consumption and lower audible noise
- VARIABLE LAMP POWER for alignment of multi-screen configurations
- LONG LIFE LAMP (up to 4000 hours) in low power ECO mode
- STYLISH AND COMPACT DESIGN to fit most applications, installed or movable
- MULTIPLE LENS OPTIONS for close-up front or rear projection and other applications
- DIRECT 1080p DVI-D HDCP compliant interface
- EXPANSION PORT for application specific signal processing
- LAN, RS232 and USB ports for control and monitoring

**The specifications and functionality of the product may change without prior notice.**

This user guide contains important information about safety precautions and the set-up and use of the projector. Please read the manual carefully before you operate the projector.

#### SAFETY

This device complies with relevant safety regulations for data processing equipment for use in an office environment. Before using the projector for the first time, please read the safety instructions thoroughly.

#### WARNING

Use only the cables and cords supplied with the projector or original replacement cables. Using other cables or cords may lead to malfunction and permanent damage of the unit.

Always use 3-prong / grounded power cord to ensure proper grounding of the unit. Never use 2-prong power cords, as this is dangerous and could lead to electrical shock.

Never open the unit. The projector contains no user serviceable parts. Refer all repairs to qualified personnel only.

Make sure that no objects enter into the vents and openings of the set. Do not spill any liquids on the projector or into the vents or openings of the unit.

Always remove lens cap before switching on the projector. If the lens cap is not removed, it may melt due to the high energy light emitted through the lens. Melting the lens cap may permanently damage the surface of the projection lens.

Do not look into the projection lens when the projector is switched on. The strong light may permanently damage sight.

Do not look into the laser beam when activated on the remote control. Laser light may permanently damage sight. Do not point laser beam on people.

Only place the projector on a stable surface, or mount it securely using an approved ceiling-mount.

Do not drop the projector.

Always operate the projector horizontally, within the range of the adjustable rear feet. Operating the unit in other positions may reduce lamp life significantly, and may lead to overheating, resulting in malfunctioning.

Always allow ample airflow through the projector. Never block any of the air vents. Never cover the unit in any way while running. Allow for sufficient distance to walls and ceilings to avoid overheating. Minimum safety distance to any side of the unit is 50 cm / 20" in any direction.

**CAUTION!** Hot air is exhausted from the rear vent. Do not place objects that are sensitive to heat nearer than 50cm / 20" to the exhaust vent.

The projector is designed for indoor use only. Never operate the unit outdoors.

Do not operate the projector outside its temperature and humidity specifications, as this may result in overheating and malfunctioning.

Only connect the projector to signal sources and voltages as described in the technical specification. Connecting to unspecified signal sources or voltages may lead to malfunction and permanent damage of the unit.

Allow the unit to cool down for 60 minutes before lamp change.

#### **INFORMATION AND WARNING ABOUT POTENTIAL HEALTH ISSUES RELATED TO MERCURY VAPOR.**

This projector uses a very powerful UHP™ lamp for illumination to produce an extremely bright image.

This technology is similar to other high-pressure discharge lamps that are extensively used in cars, street lights and other lighting appliances today. These lamps, like fluorescent lighting, contain small amounts of mercury. The amount of mercury present in a lamp is far below the limits of danger set by the authorities.

It is very important that lamps containing mercury are treated properly to minimize potential health hazards.

The UHP™ lamp, like any other high brightness projector lamp, is under high-pressure when operating. While the lamp and the projector are carefully designed to minimize the probability of lamp rupture, the lamp may break while operating and small amounts of mercury vapor may be emitted from the projector. The probability of rupture increases when the lamp reaches its nominal life. It is therefore highly recommended that the lamp is replaced when the rated lifetime is reached.

As a general precaution, secure good ventilation in the room when operating the projector. If lamp rupture occurs, evacuate the room and secure good ventilation. Children and pregnant women in particular should leave the room.

When replacing a worn lamp, dispose of the used lamp carefully by proper recycling.

Mercury is a naturally occurring, stable metallic element that may pose a safety risk to people under certain conditions. According to the Public Health Statement for Mercury published by the Agency for Toxic Substances and Disease Registry ("ATSDR", part of the United States Public Health Service), the brain, central nervous system and kidneys are sensitive to the effects of mercury, and permanent damage can occur at sufficiently high levels of exposure. Acute exposure to high concentrations of mercury vapor can cause conditions such as lung and airway irritation, tightness in the chest, a burning sensation in the lungs, coughing, nausea, vomiting and diarrhea. Children and fetuses are particularly sensitive to the harmful effects of metallic mercury to the nervous system.

Seek medical attention if any of the above symptoms are experienced or if other unusual conditions are experienced following lamp rupture.

**WARNING**

This product contains chemicals, including lead, known to the State of California to cause birth defects or other reproductive harm. Recycle properly, do not dispose of in ordinary waste!"

**REMOTE CONTROL WARNING**

Laser radiation class II product; wavelength 670nm; maximum output 1mW.

Remote control complies with applicable requirements of 21 CFR 1040.10 and 1040.11.

Remote control complies with applicable requirements of EN 60 825-1: 1994 + A11

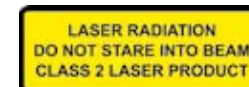

**WARNING SYMBOLS****READ USER GUIDE**

Attention! Read the user guide for further information!

**DANGEROUS VOLTAGE**

Danger! High voltage inside the product!

**HOT**

Warning! Hot surfaces!

**WAIT**

Warning! Wait until cooled down!

**MERCURY**

Warning! Lamp contains mercury! Recycle properly, do not dispose of in ordinary waste!

**UV**

Warning! UV radiation inside the product!

**RECYCLE**

Warning! Recycle properly, do not dispose of in ordinary waste!

**NO TELEPHONE**

Warning! Do not connect to telephone lines!

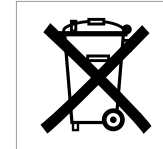
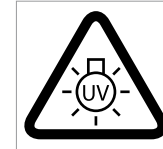
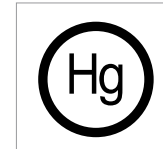
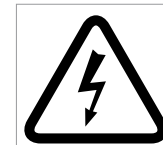

**Projector without lens**  
Lens supplied separately

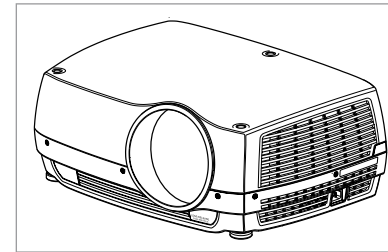

**Remote control with batteries**

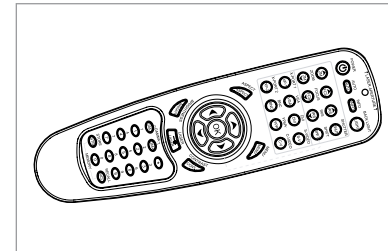

**User guide**

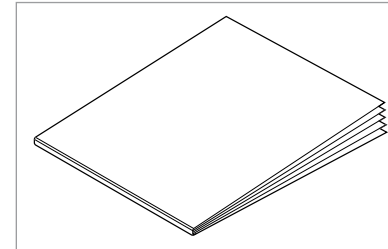

**Power Cord**  
(country dependent)

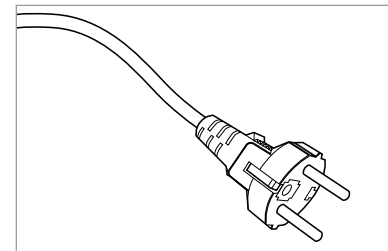

**Ceiling mount cover**

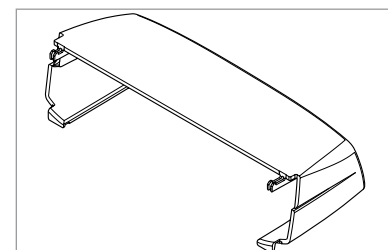

**Before Set up and Use**  
Unpack the supplied parts and familiarise yourself with the various components.



A range of fixed and zoom lenses is available to cover most applications, both front and rear. The lenses are powered and fitted with a bayonet mount for ease of installation.

**Switch off all equipment before setting-up for proper function.**

When mounting and changing lenses, be aware that the optical system is exposed to dust and foreign particles as long as the lens is not attached to the system. Do not leave the lens mount open longer than necessary to change lens. If a lens is not mounted, always insert the protection lid to avoid dust and foreign particles entering the internal optics.

**Never run the projector without lens mounted.**

- A Remove the protection lid from the bayonet mount by turning the knob anti-clockwise.
- B Remove the rear lens cap.
- C Attach the projection lens using the bayonet mount, observing the red insertion marks.
- D Turn the lens firmly clockwise until it stops with a click.
- E Remove the lens cap from the projection lens. If you switch the projector on with the lens cap in place, the lens cap may melt, damaging not only the lens cap, but also the projection lens and surrounding parts.
- F To change lens, first remove the current lens by pushing the release button and twisting the lens counter-clockwise until it comes loose.
  - Pull the lens out.
  - Insert the new lens as described above.

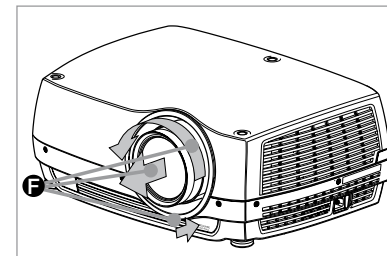
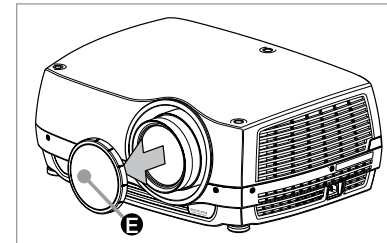
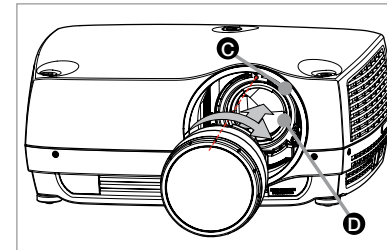
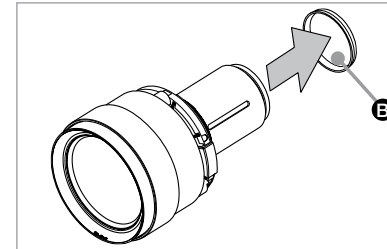
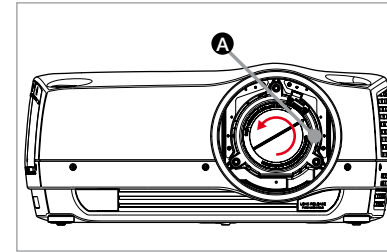

- A Lens
- B IR sensor
- C Ventilation
- D Lens release
- E Power connector

- F Keypad
- G Connector panel
- H LCD
- I Lamp lids

- J Adjustable feet
- K Security lock
- L Ceiling mount

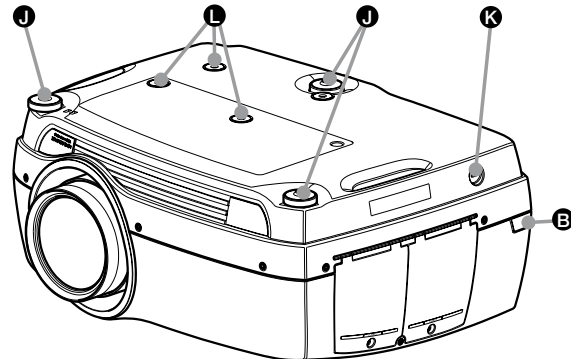
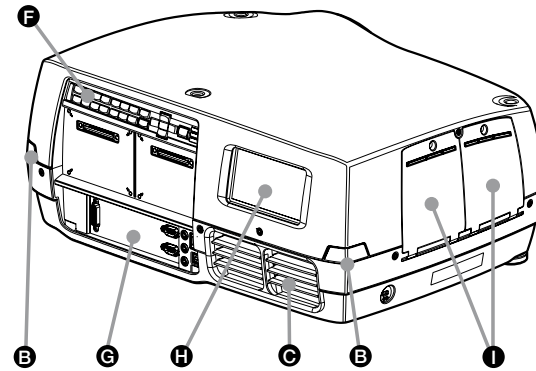
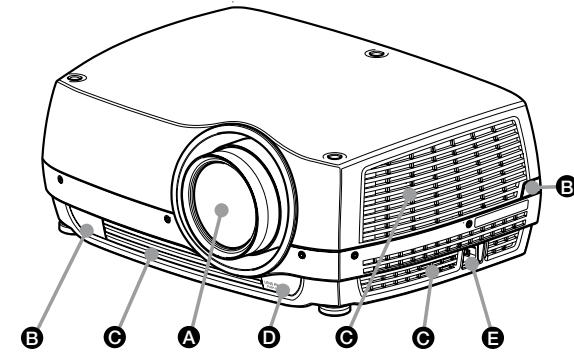

The keypad is illuminated for operation in dark environments. Available functions are illuminated in yellow while selected (active) functions are illuminated in green. Functions that are not available are not illuminated. In addition to the various functions, 10 keys are numbered 0-9. These keys are used for PIN code and other numeric functions as applicable.

#### POWER

Switches the projector between on and standby modes. Press firmly (1 sec) to switch on. Press firmly (1 sec) twice to switch off.

#### ARROW KEYS

Use the arrow keys to control lens and LCD functions.

#### LCD

Enable the backlight in the LCD.

#### TEST

Applies test images for set up and adjustment.

#### RESET

Press and hold for 2 seconds to reset settings to factory default.

#### ZOOM

Select ZOOM, then use arrow keys to zoom in or out.

#### FOCUS

Select FOCUS, then arrow keys to focus the image

#### SHIFT

Select SHIFT, then the arrow keys to shift the image up, down or sideways.

#### IRIS

Select IRIS, then arrow keys to adjust to desired combination of brightness and contrast.

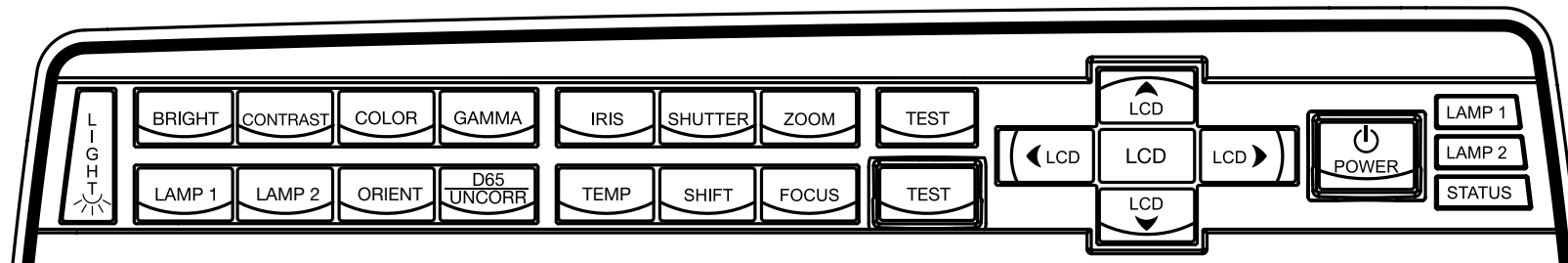

**SHUTTER**

Press SHUTTER to stop the projected image completely.

**TEMP**

Controls the color temperature of the displayed image. Use arrow keys to change.

**GAMMA**

Push GAMMA, then arrow keys to select between gamma tables.

**D65/UNCORR**

Toggle between D65 and uncorrected color temperature.

**ORIENT**

Press ORIENT, then arrow keys to cycle between desktop, ceiling, front and rear combinations.

**COLOR**

Press COLOR then arrow keys to adjust color boost.

**CONTRAST**

Press CONTRAST, then arrow keys to adjust image contrast electronically (not optical iris).

**BRIGHT**

Press BRIGHT, then arrow keys to adjust image brightness electronically (not lamp intensity).

**LAMP 1**

Press key 2 seconds to switch lamp 1 on or off. Observe wait time required after switching off before switching on again. If lamp 2 is off, pressing this key will switch lamp 1 off and lamp 2 on.

**LAMP 2**

Press key 2 seconds to switch lamp 2 on or off. Observe wait time required after switching off before switching on again. If lamp 1 is off, pressing this key will switch lamp 2 off and lamp 1 on.

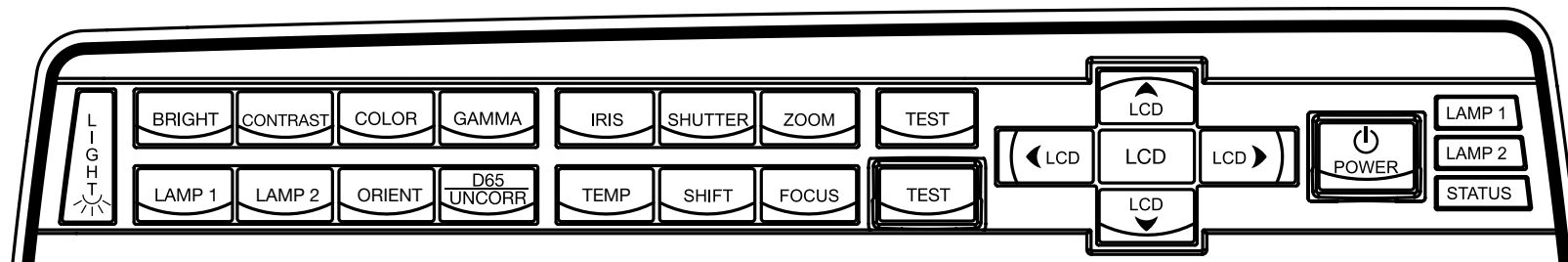

**STATUS**

Indicates the overall system status by green, yellow and red colors.

**PERMANENT GREEN LIGHT**

The projector is turned on and in normal operation.

**PERMANENT YELLOW LIGHT**

The unit is in standby mode; no source(s) connected, or the source(s) connected are inactive or switched off, thereby activating the power-save function (DPMS). You may enable or disable the power save function in the SET UP sub menu, DPMS on or off.

**FLASHING YELLOW LIGHT**

Please wait. The yellow light will flash a period after power cord is connected (10-15 sec.), and a period after going to standby mode while lamp is cooling down (approximately 45 sec.). The projector may not be turned on again until the light has turned to permanent yellow.

**FLASHING RED LIGHT**

Projector is overheated. Turn off immediately! Check if air inlets are covered or if ambient temperature is outside specifications. The projector can not be restarted unless the power cord is disconnected and reconnected again. If the projector continues to flash red, you will need to return the unit for service.

**LAMP 1, LAMP 2**

Indicate the status of each lamp by green and red colors.

**PERMANENT GREEN LIGHT**

The lamp is on and in normal operation.

**PERMANENT YELLOW**

The lamp is ready and in standby mode

**FLASHING YELLOW**

Please wait. Lamp is cooling down.

**PERMANENT RED LIGHT**

Lamp life has expired or lamp is not igniting or lamp door is open. Please change projection lamp immediately. Failing to change lamp may lead to lamp explosion.

**NO LIGHT**

No lamp inserted / connected

**LCD**

The projector is fitted with a backlit LCD screen that reports system status. You can navigate the LCD screen by using the arrow keys on the keypad.

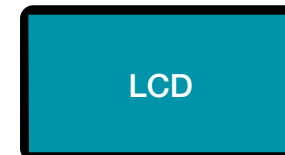
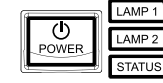
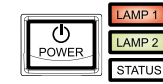
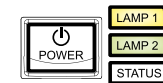
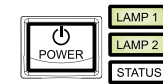
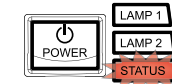
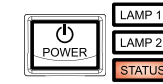
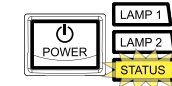
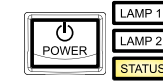
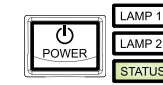

The remote control allows direct control of projector settings. The remote control is backlit for use in dark environments. It also has a datajack that allows for wired connection to the projector. When the wire is connected, the IR (infra-red) beam and internal batteries are switched off.

**POWER**

Switches the projector between on and standby modes.

**TEST**

Applies test images for set up and adjustment.

**RESET**

Press and hold for 2 seconds to reset settings to factory default.

**BACKLIGHT**

Switches the backlight on and off. The backlight will switch off automatically after ten seconds.

**LAMP DUAL**

Press key 2 seconds to switch both lamps on.

**LAMP 1**

Press key 2 seconds to switch lamp 1 on or off. Observe wait time required after switching off before switching on again. If lamp 2 is off, pressing this key will switch lamp 1 off and lamp 2 on.

**LAMP 2**

Press key 2 seconds to switch lamp 2 on or off. Observe wait time required after switching off before switching on again. If lamp 1 is off, pressing this key will switch lamp 2 off and lamp 1 on.

**CON**

Press CON up or down to adjust image contrast electronically (not optical iris).

**BRIGHT**

Press BRIGHT up or down to adjust image brightness electronically (not lamp intensity).

**COLOR**

Press COLOR up or down to adjust color boost.

**COLOR TEMP**

Press UNCORR for uncorrected color temperature

**TEMP**

Press TEMP up or down to control the color temperature of the displayed image.

**D65**

Press D65 to correct color temperature

**SHUTTER**

Toggles the mechanical shutter on and off.

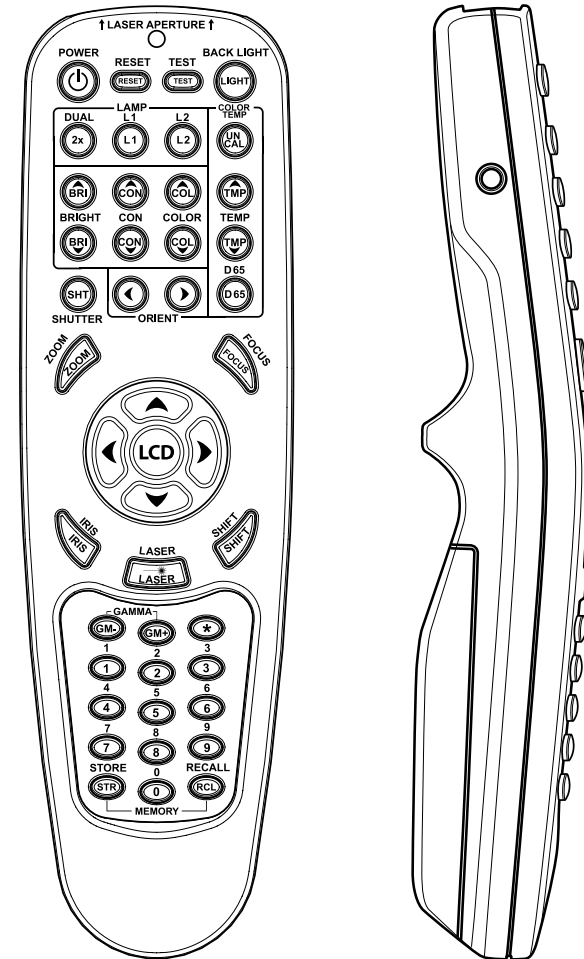

**ORIENT**

Press ORIENT left or right to cycle between desktop, ceiling, front and rear combinations.

**ZOOM**

Press the ZOOM keys to zoom the image in and out.

**FOCUS**

Press the FOCUS keys to focus the image.

**SHIFT**

Press SHIFT, then the arrow keys to shift the image up, down or sideways.

**IRIS**

Press the IRIS keys to adjust the optomechanical stop to the desired combination of brightness and contrast.

**ASPECT**

Cycles through the aspect ratios available with the current source.

**ARROW KEYS**

Use the arrow keys for various adjustments.

**LASER**

Activates the built-in laser pointer. CAUTION! Do not point laser beam at people. Do not stare into laser beam.

**LCD**

Press LCD to activate the LCD screen on the projector.

**GAMMA**

Press GM+ or GM- to select between gamma settings.

**STORE**

Press STORE, then one digit 0-9, to store user setting in memory.

**RECALL**

Press RECALL, then one digit 0-9, to recall user setting from memory.

**0-9**

Used for memory store and retrieval.

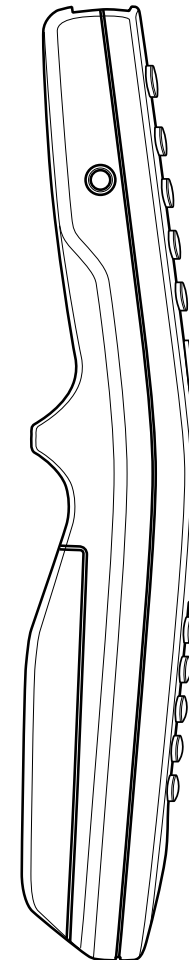
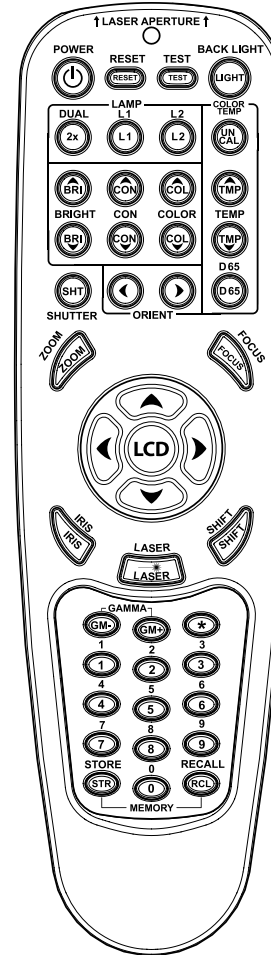

The connector panel may be illuminated by pushing the LIGHT key on the keypad.

- A **DVI-D - Digital RGB:** For a low noise computer and video image.
- B **RS 232 control in-out:** Allows for wired remote control and monitoring of many projector functions used in installation environments. The secondary output connector allows for daisy-chaining, enabling both individual and global control and monitoring of multiple projectors.
- C **RC:** Allows connection of external IR receiver or wired remote control. Triggers: 12VDC for Screen Drop and Aspect Ratio control
- D **USB - interface:** Allows for software upgrade.
- E **LAN:** Provides access to control and monitoring over a Local Area Network
- F **Mains power connector:** Use only three-prong / grounded power cord.
- G **X-PORT 1, 2:** Custom interfaces used for application-specific signal processing. Use only approved interfaces that conform to the X-PORT specification.

#### SET UP

Before setting-up, switch off all equipment. The projector may be connected a 1080p 50-60Hz image source only using DVI-D (Digital Visual Interface). Connect the RS232 or the LAN interface for control. Connect the power cord.

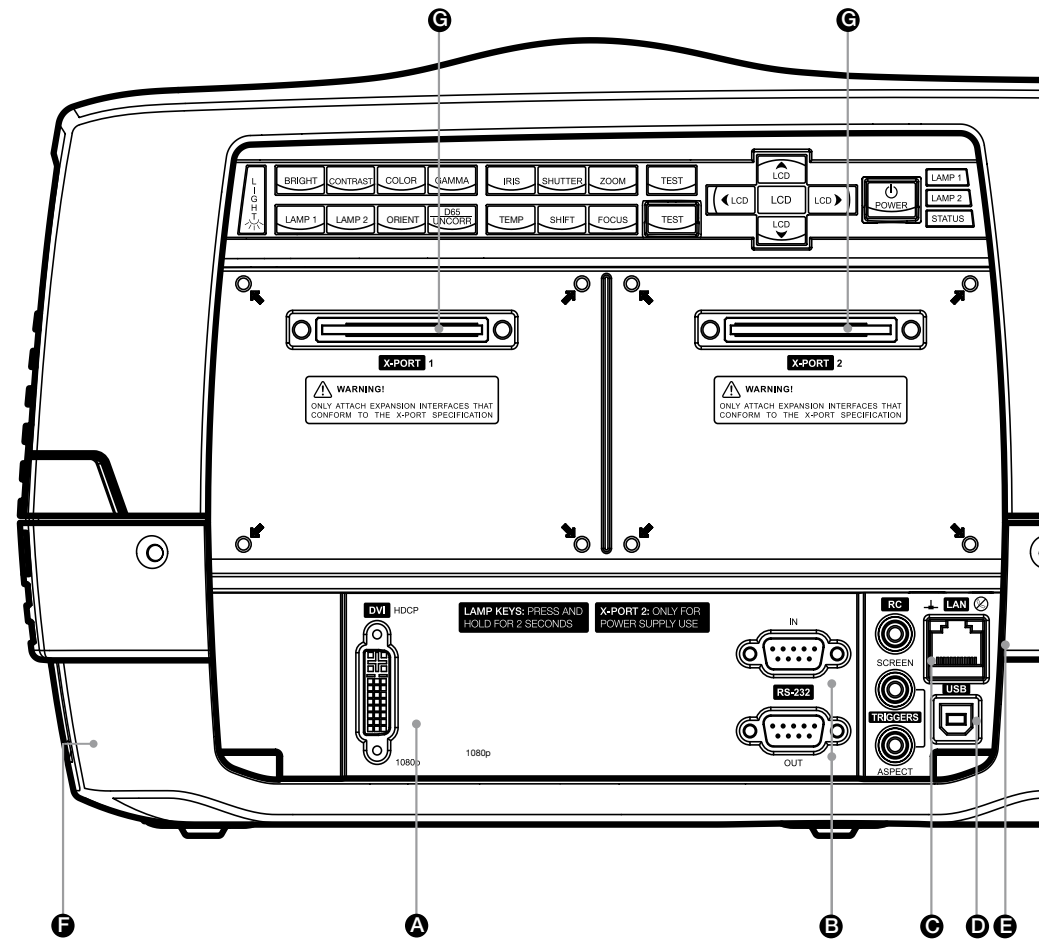



**SET UP**

Before setting-up, switch off all equipment.  
The projector may be connected a 1080p 50-60Hz image source only using DVI-D (Digital Visual Interface).  
Connect the RS232 or the LAN interface for control.  
Connect the power cord.

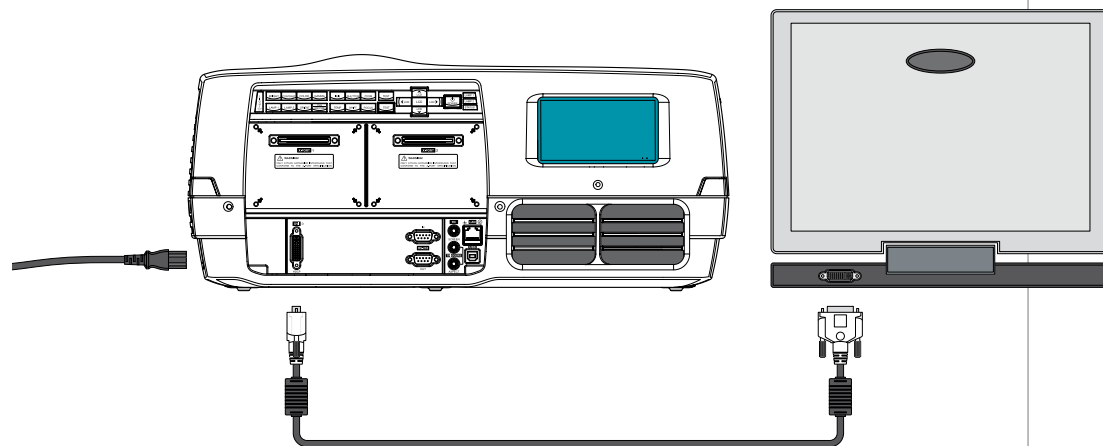

Various optical adjustments are available, depending on your choice of lens. All lens adjustments are motorized and controlled by the keypad, remote control or by RS232 or LAN.

Two kinds of lenses are available; fixed or zoom. A fixed lens has permanent focal length, or throw ratio. A zoom lens has variable focal length or throw ratio.

In addition, fixed lenses may or may not be shiftable, depending on type and model. See the specifications for the particular lens.

The throw ratio is defined as the ratio between the projection distance to the screen and the projected image width. With a fixed lens, this ratio is set. With a zoom lens, this ratio can be changed within certain limits specific to the lens in use.

On the keypad, first select lens function, then use the cursor keys to adjust. On the remote control, zoom and focus are direct keys, while lens shift is operated by first selecting SHIFT, then use the arrow keys.

A mechanical SHUTTER is employed that totally shuts off the optical image path. The shutter is directly available from the keypad and the remote control. The shutter is also in place when there is no lens attached.

Select a lens suitable for the application. A range of lenses from very wide to super telezoom is available.

Adjust the horizontal and vertical SHIFT, if applicable, in order to align the image on screen.

If a zoom lens is used, adjust the image to the right size. If a fixed lens is used, relocate the unit to achieve the right image size.

FOCUS the image properly.

Adjust the IRIS to achieve the desired optical balance between brightness and contrast. In a bright environment, brightness is usually maximized resulting in reduced contrast. In a dark environment, less light is needed and desired, while high contrast and deep blacks are appreciated.

To level the image, adjust the feet as needed by turning the feet accordingly.

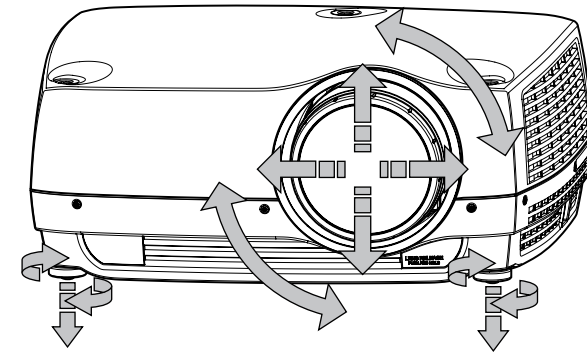

The projector is fitted with two individual projection lamps that can be run in various modes. In addition, lamps can be replaced as needed separately. This ensures an optimized cost of ownership. Individual lamp timers are maintained for each lamp.

Lamp operation mode is controlled in the LAMPS sub menu.

The projector can be ceiling mounted using an approved UL tested/ listed ceiling mount fixture, with a capacity of minimum 60 kg / 130 lbs.

For ceiling mount use M6 screws that penetrate maximum 15 mm / 0.6" into the projector body.

For proper ventilation the minimum distance from ceiling/ rear wall should be: 30/ 50 cm, 12/ 20 inch.

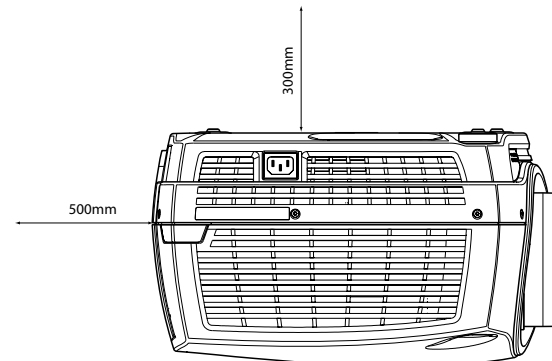
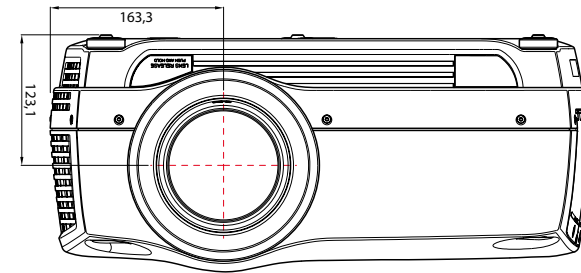
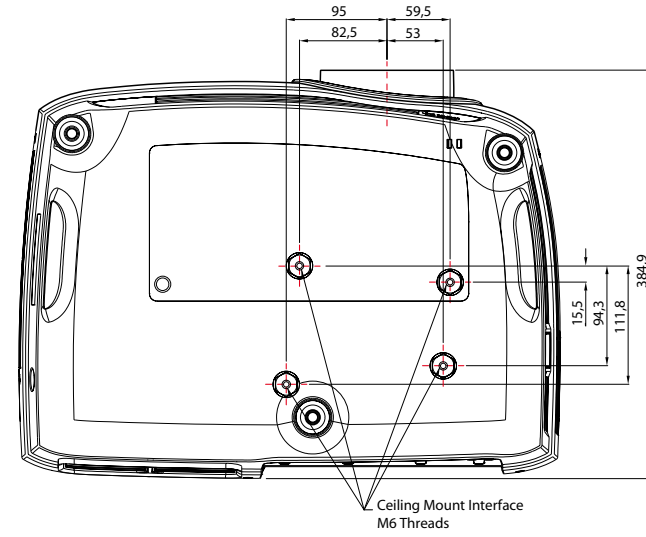

**CEILING MOUNT COVER**

The auxiliary cable cover can be mounted on the projector to conceal the interface cables and power cord when the unit is ceiling mounted.

Connect all cables and fix them in place before the cable cover is attached to the projector.

- A** Attach the cable cover to the projector by inserting the horizontal hooks on the cover in the horizontal slots on the rear of the projector.
- B** Turn the cover until the vertical hooks on the cover are inserted into the vertical slots on the rear of the projector.
- C** The cover will snap in place, to release pull the vertical hooks on the cover out of the slots, letting the cover hinge on the horizontal hooks.

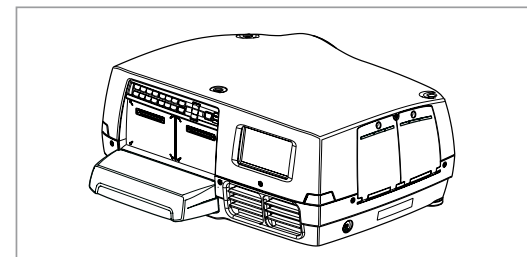
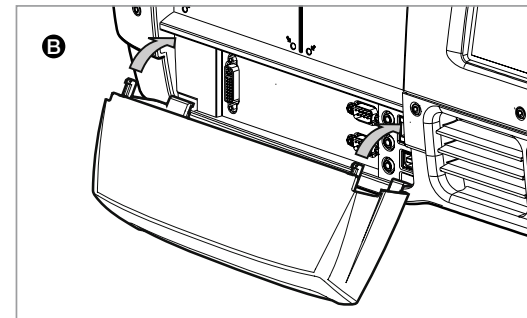
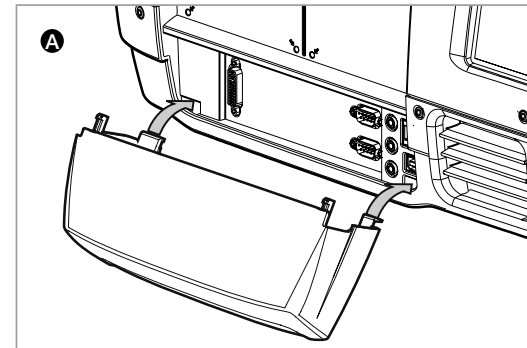
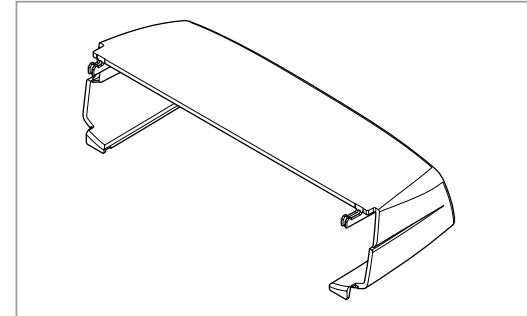

After setting-up, switch on all equipment.

After setting-up, switch on all equipment.

The projector can be controlled by the keypad on the rear, by the remote control or using the RS232 or LAN interfaces.

To switch the projector on, firmly press the POWER button on the keypad or the remote control. The STATUS indicator will turn from yellow to green when the unit is switched on. The keypad will light up so that all available functions are yellow. Functions not available will have no light. Selected functions will turn green.

If the STATUS indicator is flashing yellow, please wait until it turns permanent yellow.

To switch the projector off, firmly press the POWER button on the keypad or the remote control twice (to confirm that you really want to switch off the unit). The STATUS indicator will turn from green to flashing yellow, then yellow when switched off.

You may not switch the unit on while the STATUS indicator is flashing yellow. Please wait until the indicator is permanent yellow.

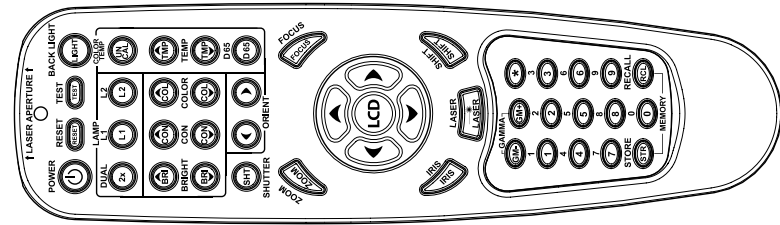
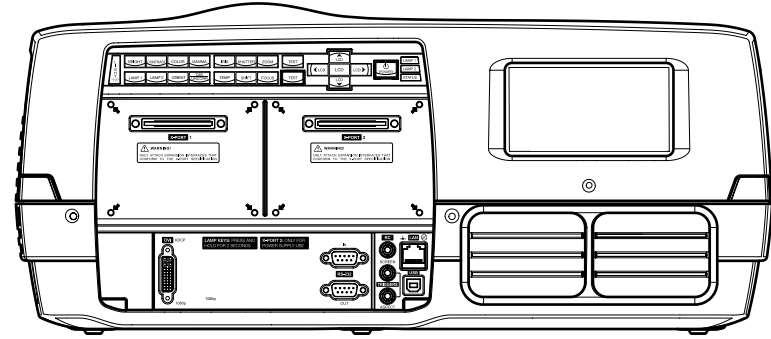

## RS 232

You may control and monitor the projector remotely through the serial RS232 control interface.

Two RS232 protocols are employed. A simple instruction set (SIS) ASCII protocol gives access to the most frequently used commands. In addition, a binary protocol is available where each command is a series of 32 bytes in one packet. The protocols allow for both SET and GET operations. To utilize GET operations the host needs a routine for receiving and interpreting incoming packets. SET-operations are used to force the projector into different modes, like setting brightness and contrast, switching between sources, etc.

A separate document "RS-232 and LAN communication protocol and command set" is available that describes the communications parameters and operational codes in detail.

## LAN

The projector can be controlled and monitored through the LAN connector as an alternative to RS232.

LAN control is available either through an embedded web page for the most frequently used commands or using the same command set as for RS232 for full access to all system controls.

**NOTE! THE PROJECTOR IS CONFIGURED WITH A DEFAULT IP ADDRESS. SEE THE SYSTEM INFORMATION AVAILABLE THROUGH THE MENU SYSTEM OR REMOTE CONTROL FOR THE ACTUAL IP-ADDRESS.**

Detailed descriptions of configuration, use and command set is described in a separate document "RS-232 and LAN communication protocol and command set".

You may consider using the LAN interface as a means of theft-detection. When the projector is removed, the LAN will be disconnected; this may be detected over the local area network and could be used to trigger an alarm.

**NO IMAGE**

**No connection:** Check if all connections are properly made.

**Source off:** Check if the equipment is powered on.

**Lamp dead:** The lamp may need replacement. Check the LAMP TIME in the UTILITIES sub menu.

**Source hibernated:** Engage the source to display and activate image.

**Notebook external screen:** Different notebook PC's use different combinations of keystrokes to enable the external graphics port.

**No lens:** Check if lens is attached properly.

**Shutter engaged:** Check if the shutter is engaged.

**Lens cap:** check if the lens cap is off!

**DARK IMAGE**

**Old, worn lamp:** The lamp may need replacement. Check the LAMP TIME in the LCD.

**Low BRIGHTNESS and CONTRAST settings:** Press AUTO or use the menu system, PICTURE sub menu for CONTRAST and BRIGHTNESS adjustment.

**FLICKERING IMAGE**

**Bad lamp:** Replace the lamp. Check the LAMP TIME in the LCD.

**UNSHARP IMAGE**

Keystone correction may have been activated inadvertently, compressing parts of the image that affect the display of fine-line graphics, text and other images of high resolution.

**Source resolution is different from projectors native resolution:**

The projector will automatically scale and resize the input format to its native resolution. Use a different scaling factor in the PICTURE sub menu, ASPECT. You may also adjust the SHARPNESS.



The projector may from time to time need cleaning. Never open the unit, as this will void any warranties. Refer service and repair to qualified personnel only.

The projector is using lamps that have a limited life time. Please refer to the LAMP CHANGE section below for further details.

Only the exterior of the unit may be cleaned. Use a damp cloth. Make sure no liquids enter the inside of the projector

Vacuum clean all the air vents (A) regularly to maintain sufficient air flow.

The projection lens (B) is sensitive to scratches. Use lens cleaning tissue, available at all photographic stores when cleaning the projection lens. Use lens cap when not in use.

#### **HEAVY DUTY AND CONTINOUS USE**

The projector contains moving parts (such as cooling fans) that have limited life-expectancies. When the projector has been used for 7 500 hours, and when the unit is used in mission-critical applications, it is recommended that the projector is given preventive maintenance by a qualified service person. This will help ensure long term stable operation.

This product contains no user serviceable parts.

If the product fails to function as expected, please first check that all connections are properly made, and that the power cord is properly connected.

Please check that the projector as well as the video and computer sources are all switched on.

Cables and cords may break over time. Try to change cables and cords, in case there is a bad or intermittent connection.

Check if the circuit breaker or fuse of your mains is intact.

In the event of product failure, please contact your reseller. You should prepare a description of the symptoms of failure you experience.

Please also state product number and serial number as printed on the label on the bottom of the projector.

**SERVICE PERSONNEL INFORMATION**

**WARNING**

Use UV radiation eye and skin protection during servicing

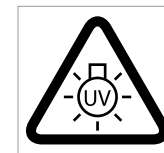

The LAMP indicators on the keypad will turn red when lamp life expires.

Change the lamp when lifetime expires. Always replace lamp with the same type and rating.

The lamp includes an electronic lamp timer that is tracking the life time of the lamp.

Allow lamp to cool down before changing. One lamp may be changed while the other lamp is operating (hot-swap).

- A Release the screw (LAMP 1) or (LAMP 2) depending on which lamp that needs to be replaced.
- B Open the lamp lid(s).
- C Turn the three locking screws a quarter turn anti-clockwise.
- D Pull the lamp out.

Replace with a new lamp in reverse order.

- E Insert a new lamp. Observe the guide pins.
- F Turn the tree locking screws a quarter turn clockwise.
- H Close the lamp lid.
- I Turn the locking screw clockwise.

#### WARNING

Be careful not to touch the protective glass when replacing the lamp house, this may cause the protective glass to overheat and break while in use.

#### WARNING

Be extremely careful when removing the lamp module. In the unlikely event that the bulb ruptures, small glass fragments may be generated. The lamp module is designed to contain these fragments, but use caution when removing the lamp module.

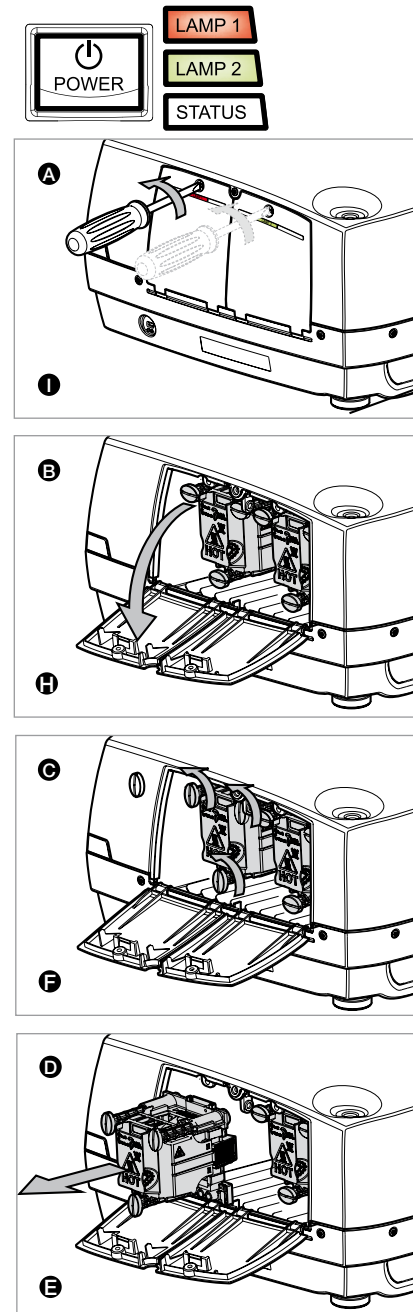

TECHNICAL DATA	
<b>PROJECTOR UNIT</b>	
Resolution	1920 x 1080, 16:9 aspect ratio
Display technology	Single chip DLP™ technology by Texas Instruments® DMD™ with DarkChip™ technology
Compatibility	1080p
Brightness	HD 1080 2500 ANSI lumen (typ), 2000 ANSI lumen (min) @ 2x250W lamp power*) 2000 ANSI lumen (typ), 1600 ANSI lumen (min) @ ECO-mode 2x200W lamp power*) 3500 ANSI lumen (typ), 2800 ANSI lumen (min) @ 2x300W lamp power*) 2800 ANSI lumen (typ), 2200 ANSI lumen (min) @ ECO-mode 2x240W lamp power*) *) Initial brightness.
Contrast	7500 : 1 B/W (max) at max IRIS, 1000 : 1 B/W (min) at min IRIS
Lamp	2x250W UHP™ dimmable to 2x200W 2x300W UHP™ dimmable to 2x240W
Lamp Life	2000 hrs (typ) to 50% brightness @ 250W (250W lamp) 4000 hrs (typ) to 50% brightness @ 200W (250W lamp) 1700 hrs (typ) to 50% brightness @ 300W (300W lamp) 2200 hrs (typ) to 50% brightness @ 240W (300W lamp)
Sound Pressure Level	Lp = 36 dB(A)/20mPa (typ), 45 dB(A)/20mPa (max) @ 20°C/68°F, sea level
Dimensions	400 x 500 x 200 mm / 15.7" x 19.7" x 7.9", excluding lens
Weight	12.6 kg / 27.8 lbs, excluding lens
Inputs	1 DVI-D female digital RGB 1 RS 232 9 pin female DSUB (control, firmware update) 1 USB-B female (control, firmware update) 1 LAN RJ-45 female (control, firmware update) 1 Remote Control 3.5 mm female stereo jack
Outputs	2 Trigger 3.5 mm female stereo jack, 12 V @ 80 mA Max 1 RS 232 9 pin male DSUB
Power	90-260 VAC, 50-60 Hz, 840W @ 2x250W 940W @ 2x300W
Energy dissipation	2866BTU/h @ 2x250W 3200BTU/h @ 2x300W
MTBF	17500 hrs
Conformance	CE, FCC A, CSA(C,US)
Temperature operating	0-40°C / 32-104°F, 0-1500 m / 0-4950 ft 0-35°C / 32-95°F, 1500-3000 m / 4950-9900 ft
Temperature storage	-20 - 60°C / -4 - 140°F
Humidity operating	20-90% RH, non-condensing
Humidity storage	10-95% RH, non-condensing

TECHNICAL DATA	
<b>LENSES</b>	
Short fixed lens	<p>f = 16,3 mm F = 2.1 - 6.5</p> <p>throw ratio (distance : width) = 0.79 : 1</p> <p>throw distance = 0.5 - 2.5 m / 1.65 - 8,25 ft. horizontal shift = +/- 1% (fine adjust only) vertical shift = +/- 1% (fine adjust only)</p>
Medium fixed lens	<p>f = 23,95 mm F = 2.1 - 6.5</p> <p>throw ratio (distance : width) = 1.15 : 1</p> <p>throw distance = 1 - 15 m / 3.3 - 50 ft. horizontal shift = +/- 90% vertical shift = +/- 105%</p>
Wide angle zoom lens	<p>f = 25,6 - 33,2 mm F = 2.1 - 6,5 zoom ratio = 1.3 x</p> <p>throw ratio (distance : width) = 1.23- 1.60 : 1</p> <p>throw distance = 1 - 15 m / 3.3 - 50 ft. horizontal shift = +/- 90% vertical shift = +/- 105%</p>
Standard zoom lens	<p>f = 33,2 - 48,1 mm F = 2.1 - 6,5 zoom ratio = 1.5 x</p> <p>throw ratio (distance : width) = 1.60 : 1 - 2.32 : 1</p> <p>throw distance = 2 - 15 m / 6.6 - 50 ft. horizontal shift = +/- 90% vertical shift = +/- 105%</p>
Long zoom lens	<p>f = 48,9 - 78,4 mm F = 2.1 - 6,5 zoom ratio = 1.6 x</p> <p>throw ratio (distance : width) = 2.36 - 3.78 : 1</p> <p>throw distance = 2 - 30 m / 6.6 - 100 ft. horizontal shift = +/- 90% vertical shift = +/- 105%</p>
Very long zoom lens	<p>f = 78,3 - 136,2 mm F = 2.1 - 6,5 zoom ratio = 1.75 x</p> <p>throw ratio (distance : width) = 3.78 - 6.57 : 1</p> <p>throw distance = 4 - 40 m / 13.2 - 132 ft. horizontal shift = +/- 90% vertical shift = +/- 105%</p>
Specifications subject to change without prior notice. All values may vary up to +/- 20%.	

**CONNECTORS**

Computer DVI	RS-232 in	RC in	LAN
<b>DVI-D</b>	<b>9 PIN DSUB FEMALE</b>	<b>3,5mm stereo mini jack</b>	<b>RJ 45</b>
1 TMDS Data 2-	1 NC	TIP: 5V DC	1TX+
2 TMDS Data 2+	2 RXD	RING: SIGNAL	2TX-
3 TMDS Data 2/4 Shield	3 TXD	STEM: GND	3RX+
4 Not used	4 NC		4GND
5 Not used	5 GND		5GND
6 DDC Clock	6 NC		6RX-
7 DDC Data	7 NC		7GND
8 NC	8 NC		8GND
9 TMDS Data 1-			
10 TMDS Data 1+			
11 TMDS Data 1/3 Shield			
12 Not used			
13 Not used			
14 +5V Power			

RS-232 out	Aspect	USB
<b>9 PIN DSUB MALE</b>	<b>3.5mm mini jack</b>	<b>DIGITAL USB</b>
1 NC	TIP: 12V DC	1 VCC
2 TXD	80mA max	2 -Data
3 RXD	STEM: GND	3 +Data
4 NC		4 GND
5 GND		
6 NC		
7 NC		
8 NC		

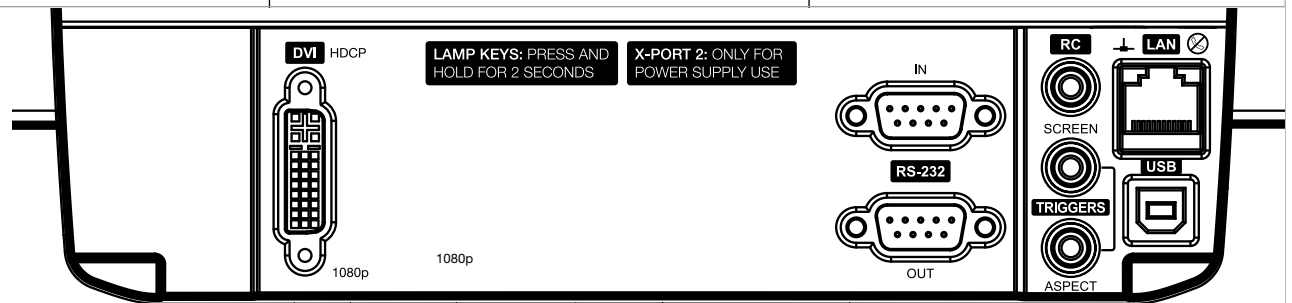

1080p

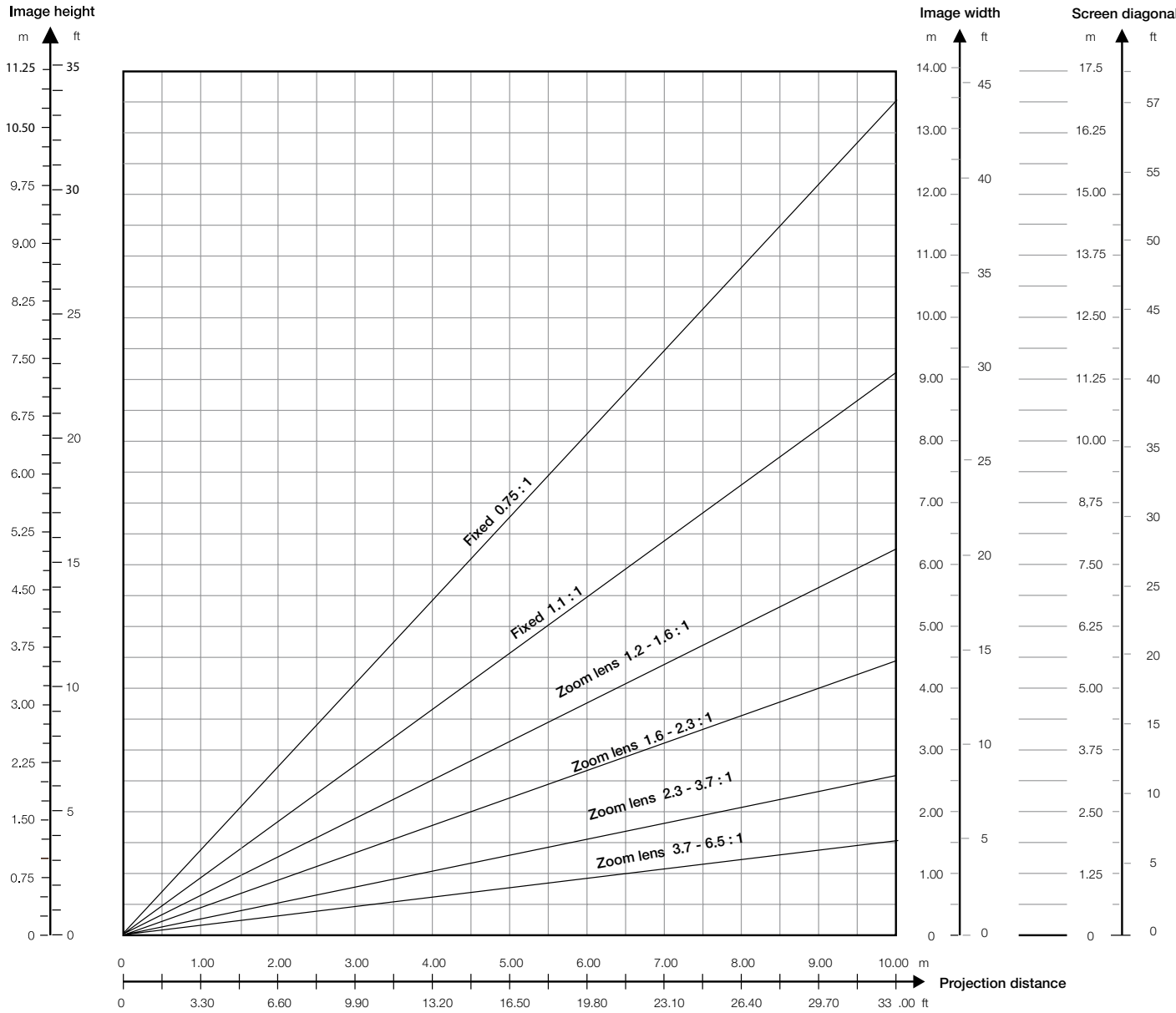



english

**FCC**

This equipment has been tested and found to comply with the limits for a Class A digital device, pursuant to part 15 of the FCC Rules. These limits are designed to provide reasonable protection against harmful interference when the equipment is operated in a commercial environment. This equipment generates, uses, and can radiate radio frequency energy and, if not installed and used in accordance with the instruction manual, may cause harmful interference to radio communications. Operation of this equipment in a residential area is likely to cause harmful interference in which case the user will be required to correct the interference at his own expense.

**EN 55022 WARNING**

This is a Class A product. In a domestic environment it may cause radio interference, in which case the user may be required to take adequate measures. The typical use is in a conference room, meeting room or auditorium.

**CANADA**

This Class A digital apparatus complies with Canadian ICES-003.  
Cet appareil numérique de la classe A est conforme à la norme NMB-003 du Canada.



